



*PHYSICAL SECURITY PRODUCTS*

# RHINO



Rhino safes are strong, compact and built to last. These safes can be easily accommodated in all residences. Also available in an electronic variant which has a digital locking system.

## FEATURES



- Heavy plate door with solid steel bearing block
- 2 shooting bolts
- Drill-resistant armour plate for shielding lock and bolt in door
- Opens only with a Godrej high precision 6 lever key

### Related Information

Specifications	All Dimensions are in mm
Dimensions (H x W x D)	420 x 460 x 395
Body Thickness (Wall)	2.5
Body Thickness (Door)	5
Weight (kg)	40
Volume (litres)	15

# MATRIX MECHANICAL



Matrix is one of the strongest home safes available in the market. A fire and burglar resistant safe that looks sleek and is easy to operate. Ideal for cash, jewellery, watches, silver, documents and other valuables.

## FEATURES

- Burglar & fire resistant.
- Strong double walled construction with armoured plate in door and body for drill protection
- Shooting bolt mechanism
- Adjustable shelves
- Interior carpet
- Six lever lock: Equipped with a dual control six lever Godrej key lock.
- Two Key System: For additional security, the safe opens with two keys.

### Related Information

### Related Information

Specifications	1814	2414	3016
Dimensions (H x W x D)	588 x 486 x 546	740 x 486 x 546	892 x 536 x 546
Body Thickness (Wall)	65	65	65
Body Thickness (Door)	130	130	130
Weight (kg)	155	185	230
Volume (litres)	50	66	94

All Dimensions are in mm

# MATRIX MANUAL WITH I-WARN



**I-Warn**  
Instant phone alerts  
upon tampering



**I-Warn**  
Alarm activates  
upon tampering

- Burglar & fire resistant
- Strong double walled construction with armoured plate in door and body for drill protection
- Shooting bolt mechanism
- Adjustable shelves
- Interior carpet
- Six lever lock: Equipped with a dual control six lever Godrej key lock.
- Two Key System: For additional security, the safe opens with two keys.

Related Information

Related Information

## I-Warn Unit



An alarm goes off in case there is an attempt to tamper with the safe. The user also receives a phone call alerting him of a break-in attempt on the safe.

## Features of I-Warn Unit

- ↳ Specially designed UL Listed panel
- ↳ Wireless connectivity @ 433 Mhz
- ↳ Vibration sensor to detect attack
- ↳ In-built 85 db buzzer for local alarm
- ↳ Master and User code for activation and deactivation

## Optional Accessories

### GSM Module for I-Warn



#### Key Features

- ↳ Stores up to 8 telephone numbers
- ↳ Sends pre-recorded voice messages and SMSs to saved numbers
- ↳ Voice messages of up to 16 seconds long may be recorded
- ↳ Wired connectivity to the panel with wire-cut detection

### Hooter for I-Warn



#### Key Features

- ↳ Sounds an alarm with an intensity of 110 dB
- ↳ Wired connectivity to the panel with wire-cut detection

Specifications	1814	2414	3016
Dimensions (H x W x D)	588 x 486 x 546	740 x 486 x 546	892 x 536 x 546
Body Thickness (Wall)	65	65	65
Body Thickness (Door)	130	130	130
Weight (kg)	155	185	230
Volume (litres)	50	66	94

All Dimensions are in mm

# SAFIRE - MECHANICAL



Safire is a contemporary fire resistant safe. It is designed to provide 2 key locks protection of documents and data against fire.

## FEATURES



- Designed to withstand fire for up to 90 minutes
- 2 key locks
- Tongue and groove construction to prevent hot gases / smoke from seeping in
- Certified & listed at SP, Sweden and UL, USA

### Related Information

All Dimensions are in mm

Specifications	40 L (Vertical)	30 L (Horizontal)
Dimensions (H x W x D)	560 x 422 x 491	385 x 507 x 491
Body Thickness (Wall)	58.5	58.5
Body Thickness (Door)	82	82
Weight (kg)	82	70
Volume (litres)	40	30

# CASH BOX



## FEATURES

- Body built out of single plate using multibend construction for greater strength and rigidity.
- Rigid steel lid , double bent along its locking edge and mounted on solid concealed pivots, making it virtually tamper-proof.
- Sturdy locking mechanism actuated by 6-lever Godrej unpickable lock with stainless steel keys in duplicate.
- Oven-baked enamel paint for attractive and lasting finish.

DIMENSIONS (mm)			
	H	W	D
SMALL	125	305	225
BIG	150	355	255
Net Weight: 13 Kgs.			
Gross Weight: 13.5 Kgs.			

# PREMIUM COFFER



## FEATURES

Premium Coffers are designed to protect your handy cash and valuable possessions, be it for business or home use. Premium coffers come with 2 shooting bolts that ensure total security.

### Features



Dual tone powder coated finish

Heavy plate door with solid steel bearing block

2 Shooting bolts

Rear end of the door acts as a continuous bolt

Resistant shield

Armoured with hammer and drill resistant shield

Can be fixed on a table or shelf, or embedded into a wall

Available in 2 colours : Brown & Gold & Blue & Silver

Solid steel plate door

Single plate multibend construction

Related Information

Locking system





Sturdy bolt work secured by a 6-lever unpickable lock.



Optional dual control Gordian lock.

Usage

Banks, Private Safe Deposit Vaults, Financial Institutions, Offices, Factories and Warehouses, Hospitals, Refineries, Allied Industries, Jewellers, Post offices, Homes, Shops, Hotels, Multistorey Buildings.

Specifications

Dimensions HxWxD (mm)	255 x 360 x 325 410 or 210 + 200 (locker)mm
Net Weight (kg)	20
Gross Weight (kg)	20.5
Volume (Ltr.)	20
Tolerances: Weight: +/- 3%	
Dimensions: +/-1%	

All dimensions & Weights are in metric system and are approximate.

# PREMIUM COFFER V1 RED



## FEATURES

- Design that exudes elegance
- Equipped with a Godrej 6 Lever Lock
- Twin strong movable shooting bolts for extra protection
- Can be bolted on your wardrobe or dressing table

### Related Information

Specifications	
Dimensions (H x W x D)	250 x 350 x 270
Body Thickness (Wall)	5
Body Thickness (Door)	12
Weight (kg)	20
Volume (litres)	14

All Dimensions are in mm

# CERES SAFES



Ideal for safeguarding valuables at home, Ceres is a contemporary safe. Its strong and compact exterior provides exceptional protection, and it looks great as well.

## FEATURES



- 2 shooting bolts
- Removable shelf
- Sleek and aesthetic design
- Dual tone powder coated finish

## Related Information

Specifications	
Dimensions (H x W x D)	250 x 350 x 250
Body Thickness (Wall)	2
Body Thickness (Door)	4
Weight (kg)	12
Volume (litres)	14

All Dimensions are in mm

## Usage

Ceres safes can be used for homes and small offices to keep your precious valuables safely. Its strong and compact exterior is definitely value for money

# CERES V1 GREY



## FEATURES

- Stunning Design with Powder Coated Finish
- Twin strong movable shooting bolts for extra protection
- Offers extreme resistance, cannot be compromised easily
- Can be anchored on your wardrobe or dressing table

### Related Information

Specifications	
Dimensions (H x W x D)	255 x 360 x 340
Body Thickness (Wall)	2
Body Thickness (Door)	4
Weight (kg)	12
Volume (litres)	20

All Dimensions are in mm



A perfect combination of strength and class, Citadel is a fire and burglar resistant safe that is aesthetically pleasing too.

## FEATURES



- Fully welded multi-bend body with double-walled construction
- 2 way 4 shooting bolts
- Opens only with a Godrej high precision 6 lever key
- Dual tone powder coated finish
- Adjustable shelf for better space utilization

### Related Information

### Related Information

Specifications	40	45
Dimensions (H x W x D)	330 x 450 x 385	470 x 490 x 415
Body Thickness (Wall)	3	3
Body Thickness (Door)	6	6
Weight (kg)	40	55
Volume (litres)	28	33

All Dimensions are in mm

# CITADEL V1 GREY



## FEATURES

- A fully welded multi-bend body with double-walled safe
- 3-way locking arrangement
- Opens only with a Godrej high precision dual control lock
- A dignified and lasting look and an elegant handle that complements any décor
- Attractive powder-coated finish with dualtone colour-off white on door & metallic grey on the body
- One adjustable shelf for better utilization of space

### Related Information

### Related Information

Specifications	40	45
Dimensions (H x W x D)	330 x 450 x 385	470 x 490 x 415
Body Thickness (Wall)	3	3
Body Thickness (Door)	6	6
Weight (kg)	40	55
Volume (litres)	28	43

All Dimensions are in mm

# CENTIGUARD



Centiguard safes are designed to withstand the most intense fires and keep your documents well protected. Ideal for safeguarding paper documents from fire.

## FEATURES



- Designed to withstand fire for up to 120 min.
- 2 key locks
- Certified & listed at SP, Sweden and UL, USA
- Tongue and groove construction to prevent hot gases / smoke from seeping in
- Provided with a lockable drawer and an adjustable shelf
- Powder coated finish for surface protection

### Related Information

Specifications	445	560	720	1060
Dimensions (H x W x D)	649 x 505 x 540	764 x 590 x 590	924 x 590 x 590	1264 x 590 x 590
Body Thickness (Wall)	70	70	70	70
Body Thickness (Door)	114.5	114.5	114.5	114.5
Weight (kg)	118	186	218	290
Volume (litres)	49	90	115	170

All Dimensions are in mm

# POPULAR SAFES

The Godrej logo is located in the top-left corner of the image. It features the word "Godrej" in a stylized, cursive font with a color gradient from green to red.

Safes with a dual control, high-precision 6-lever locks for total safety of your valuables.

A range of burglary resistant safes to store all your daily cash transactions with safety and security.

## FEATURES

- Fully welded multi-bend body
- Heavy plate door hinged on strong pivots in solid-steel bearing blocks
- Three shooting bolts that act like one strong vertical bolt when the door is closed
- A twelve tank anti-corrosion and scratch-resistant treatment

Multi-coat paint finish, on a rust-inhibiting primary coat

Available with a coin slot option, with a removable and lockable flap for day and night options.

## RELATED INFORMATION



# USAGE

Financial Institutions, Offices, Factories and Warehouses, Hospitals, Jewellers, Post offices, Residential Colonies, Homes, Shops, Hotels, Multi-storey Buildings.

## LOCKING SYSTEM

↓  
Safes are fitted with a dual control, high-precision 6-lever lock operated by two keys.

↓  
Drill defeat shield to protect vital parts of the lock and dead locking device.

## ACCESSORIES

↓  
One fixed and one removable shelf.

↓  
Locker with a flap door under the fixed shelf, to store items that need additional security.

Financial Institutions, Offices, Factories and Warehouses, Hospitals, Jewellers, Post offices, Residential Colonies, Homes, Shops, Hotels, Multi-storey Buildings.

Locking system

↓  
Safes are fitted with a dual control, high-precision 6-lever lock operated by two keys.

↓  
Drill defeat shield to protect vital parts of the lock and dead locking device.

Accessories

↓  
One fixed and one removable shelf.

↓  
Locker with a flap door under the fixed shelf, to store items that need additional security.

Related Information

Models		685 mm (27-POP)	560 mm (22-POP)
Height:	Outside	685	560
	Inside	615	490
Width:	Outside	535	460
	Inside	530	455
Depth:	Outside	510	460
	Inside	420	370
		0.14	0.08

# DEFENDER PLUS SAFES



The Defender Plus Range of Safes from the house of Godrej counters the most sophisticated security threats.

## FEATURES

- **What makes Defender Safes the best?** : Underwriters' Laboratory, USA and BIS India have approved the Defender Plus range of Safes. This range is defined by the unique features like two-step door design, Higher thickness of barrier material made of composite barrier slabs such as Double Duty Barrier Material (DDB), Torch and Drill Resistant Matrix (TDR), armour plating and the unique Drill Defeat Shield that offers more protection against burglary and fire.
- **The Strong Seamless Body** : Fully welded multi corner bend construction without a single rivet makes the body an integral whole. All five sides and the door of the Godrej Defender Plus Safes (TL 30 range) are armoured with a specially formulated Double duty barrier material that is encased between strong outer and inner steel bodies. This provides massive resistance to attacks of sledgehammers, power drills and chisels, and also helps withstand the impact of a fall from upper floors. For higher grades of safes, the DDB is further fortified by a TDR matrix which offers excellent protection from torch, drill and tool attacks. The safes are further fortified by armour plating on all 6 sides.

The overall body thickness on all five sides is 100 mm (approx.), which offers as much resistance as 25 mm solid steel. The special outer body thickness of 5 mm plate offers extra protection, thus making the Godrej Defender Plus Safe Unique.

- **Locking Mechanism** : The Godrej Defender Plus range of safes are fitted with Godrej's superior quality, dual control, high precision locks which are unpickable and only the original keys will open them.

Highly sensitive re-locking device on both locks prevents burglary by instantly deadlocking the Door if the locks are tampered with either mechanically or by using liquid explosives.

Unique Drill defeat shields protect vital parts of the lock and dead locking device.

Optionally, a UL/VdS listed Group II M 3-wheel combination lock can also be fitted in addition to the 2 key locks.

Option for fitting Time Lock available in larger sizes.

Option of Electronic Combination Lock and Biometric Lock also available.

Certification

➤

UL Listed Safes : The TL-30 range of safes are listed and certified by Underwriters' Laboratory, U.S.A. as per UL-687 standards.

➤

BIS Listed Safes : Also available are a range of safes as per TRTL 15X6 / TRTL 60 X 6 of BIS standards.

Models		26	31	41	49	61SD	61DD	81
<b>Technical Information</b>								
Outside:	Height (H)	660	790	1040	1245	1550	1550	2045
	Width (W)	530	635	635	785	785	1090	950
	Depth (D)	575	675	675	725	725	725	880
Inside:	Height (h)	460	590	840	1045	1350	1350	1845
	Width (w)	330	435	435	585	585	890	750
	Depth (d)	295	395	395	440	440	440	595
Internal cubic capacity- cubic metre		0.045	0.1	0.144	0.268	0.346	0.526	0.823
Door Swing (S)		400	500	500	650	650	500	815
Overall depth with door at 90° (OD)		960	1165	1165	1365	1365	1215	1690
Overall width with door at 180° (OW)		850	1055	1055	1360	1360	1935	1690
Overall Thickness (OT) of door		150	150	150	155	155	155	155
Floor loading - kg/m <sup>2</sup>		1425	1530	1915	2025	2460	2330	3100
Fittings:								
Shelves-Adjustable/Removable only *		One *	One *	Two	Two	Three	Three	Four
Drawers/Lockers *		One *	One	One	Two	Two	Three	Two
No. of Dual-control lock		1	1	1	2	2	3	2
No. of Shooting bolts		6	6	8	8	8	16	10
Drawers/Locker internal dimensions								
Height		115	110	110	110	110	110	110
Width		300	390	390	250	250	250	335
Depth		225	325	325	365	365	365	525
Shipping particulars:								
Case Height		875	1000	1255	1460	1765	1765	2260
Case Width		640	750	750	895	895	1200	1100
Case Depth		750	850	850	900	900	900	1100
Weight (without packing) - kgs.		395	601	759	1076	1261	1628	2520
Weight (with packing) - kgs.		408	618	778	1174	1390	1748	2700

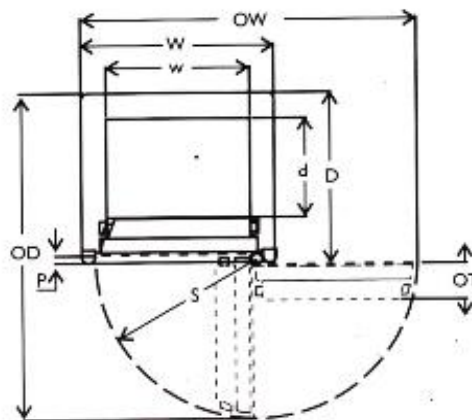
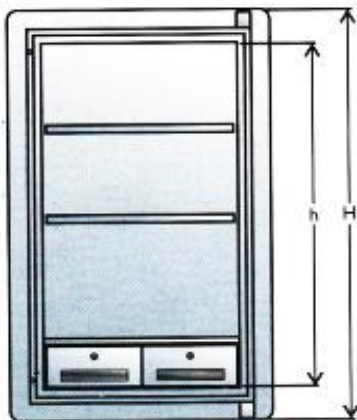

# DATALINE - DATA SAFES



Complete protection from fire, dust, heat, moisture, electrostatics and accidental damage.

## FEATURES

- Computer Grey, Polyurethane (PU) paint.
- Available in various sizes - 53ltrs, 90ltrs, & 370ltrs.
- Protects from fire, dust, heat, moisture, magnetic fields, electrostatics and accidental damage.
- Designed to withstand temperatures up to 1000 degree C for over an hour.
- Average Internal temperature below 30 degrees C after 60 minutes of testing in furnace.
- Average internal temperature below 44 degree C after a 6-hour soak out period.
- Adjustable shelves and pull out trays are available optionally.
- Dataline (M) can also be provided with lockers.

### Related Information

#### Usage

Banks, Private Safe Deposit Vaults, Financial Institutions, Offices, Factories and Warehouses, Petrochemical Industries, Brokers, Jewellers, Hotels and Hospitals.

#### Locking system

➤

Two 10-lever high security Godrej Cylindrical Locks.

➤

Snap shut mechanism.

#### Certification

➤

Certified at CBRI Roorkee for Data protection as per IS: 14562 for 1 hour. Fire endurance and 1 hr. Fire & Impact Test.

➤

Designed as per UL-72 Class 125 specifications for 1-hour rating.

Product	Ext. Dim. in mm (H x W x D)	Int. Dim. in mm (h x w x d)	Weight in Kgs.	Volume in litres	CAPACITY		
					3.5" floppy diskettes	Sony 90P/90M Data cartridge	3M/DC 6150 Data cartridge
Dataline Datasafe - 10 ltr.	561 x 425 x 476	250 x 175 x 250	110	10.94	200 nos.	120	22
Dataline Datasafe - 53 ltr.	726 x 555 x 661	400 x 305 x 435	155	53.07	1000 nos.	618	102
Dataline Datasafe - 90 ltr.	826 x 655 x 676	500 x 405 x 450	275	91.13	1640 nos.	1040	184
Dataline-M Cabinet - 370 ltr.	1875 x 850 x 783	1510 x 560 x 440	830	372.06	7000 nos.	3600	700

# FIRE RESISTANT FILING CABINETS



In minutes, a fire can wipe out your business and change your life. It takes very little time to start a fire, a carelessly thrown cigarette butt, and an electrical short circuit, things that happen through sheer carelessness, events that are not even in anyone's control.

Fire devours paper rapidly and greedily. It takes lifetime's work to set up a business but a few minutes to destroy it. The record of transactions, policies, accounts receivable and payable, statements, licenses, agreements, formulae and blue prints are invaluable. You can get compensation through insurance, but once your vital documents turn to ashes, there is absolutely no recovery. So, make a wise decision before it is too late.

Features

➤

**More protection through robust construction** : The body of a Godrej Fire Resisting Filing Cabinet is designed for greater strength & rigidity. It is fabricated using modern precision tooling and sheet metal working equipment. Only prime quality galvanized steel is used. The thickness of the steel addresses both the structural strength requirements as well as the need to minimize absorption thereby conduction of heat. The cabinet has separate inner and outer shells reinforced in vital places to form a rigid integral body. So, if a floor collapses due to fire, the cabinet can withstand the fall and the avalanche of debris on it.

➤

**Formidable resistance to heat** : Godrej Fire Resisting Filing cabinets have unique features which offer unequalled resistance to heat from fires or hot gases.

➤

**Tongue & Groove Construction** : A special Tongue-and-groove construction employed to prevent the passage of flames and hot gases to the interior of the drawer.

➤

**All round protection for each drawer** : Each drawer of the Fire Resisting Cabinet has an independent five-sided enclosure heavily insulated with the unique Godrej fire resisting compound.

➤

**Independently tested for performance** :

↕

The Godrej Fire Resisting Filing Cabinets, have the unique distinction of having been successfully tested at the prestigious Underwriters Laboratories Ltd. ( UL ) of Chicago, USA for 1 hr & 2hr ratings for Fire Endurance, Fire and Impact as well as Explosion Hazard as per UL : 72 Class 350.

↕

The 2-hour fire-impact test at Underwriters Laboratories USA involved heating the cabinet, in a specially designed furnace to almost 1850 F, dropping it from a height of 9 meters (30 feet) and subsequently heating it again in an inverted position to almost 1850 F. Even after the entire duration of the test, the paper records inside the drawers were found to be usable, demonstrating its superior fire and impact resisting capabilities.

➤

**Effortless movement of drawers** : The drawers of the Godrej Fire Resisting Filing Cabinet move on specially designed double extension telescopic slides for effortless movements.

➤

## Locking mechanism :

Emergency latch: Each drawer of the Godrej Fire Resisting Filing cabinet is provided with a self-closing latch which enables users to shut the drawers almost instantaneously during emergencies.

A sturdy automatic locking mechanism that is centrally controlled by one Godrej high-precision 6-lever dual control lock, which serves all the drawers. This lock is fitted on the topmost drawer allowing individual drawers to be kept open for use while the rest are locked.

A UL Listed 3-wheel numerical combination lock / Electronic Combination lock on the top drawer can be provided (Optional) in lieu of/in addition to the high-precision 6-lever dual control lock, if specified at the time of placing of order. This lock offers a choice of nearly 10,00,000 combinations for setting and resetting.

Individual locks on all drawers can also be provided (optional) at an extra cost.

**Drawer Isolation Catch** A simple, foolproof isolation catch provided on the right hand side of each drawer permits its independent use and locking.

**Color Options** Ash Grey / Moonlight Grey, RAL 9001, RAL 7035.

SPECIFICATIONS								
Cabinet	1 Hr rated FRFC		1 Hr rated LD FRFC		2 Hr rated FRFC		2 Hr rated LD FRFC	
	HxWxD	Wt	HxWxD	Wt	HxWxD	Wt	HxWxD	Wt
4 Drawer	1600 X 552 X 805	470	1600 X 552 X 670	370	1608 X 560 X 835	510	1608 X 560 X 700	425
2 Drawer	836 X 552 X 805	240	836 X 552 X 670	185	844 X 560 X 835	260	844 X 560 X 700	200
Drawer	280 X 388 X 635		280 X 388 X 499		280 X 388 X 635		280 X 388 X 499	

\*All dimensions are in mm and weight in Kg. Tolerance - weight:  $\pm 10\%$  and dimensions  $\pm 5\%$ .

# FIRE RESISTING RECORD CABINET



## Features

- ↳ **Recorded protection a new dimension** : Godrej has designed its Fire Resisting Record Cabinet (FRRC) to provide valuable fire protection and adequate storage space to keep the bulkiest of ledgers, box files, unwieldy bound reports and other vital documents safely and conveniently.
- ↳ **Solid construction for structural strength** : The Godrej FRRC has a sturdy double-walled body, reinforced at vital points, and door of multibend construction fabricated from prime quality steel.
- ↳ **In-situ insulation for reliable fire resistance** : The Godrej FRRC has a highly efficient insulation of a special fire resisting compound, which is solid and stable, and poured in-situ between the two walls of the body and the door giving it a 75mm (2.94") thick wrap-around protection against fire.
- ↳ **Tongue-and-groove construction** : The door has a specially designed tongue-and groove construction which creates a diversion in the passage of flames and hot gases, preventing them from entering the cabinet.
- ↳ **Independently tested for performance** : The Godrej FRRC has successfully withstood severe fire and impact tests conducted at the Central Building Research Institute, Roorkee, Uttar Pradesh, India - the only accredited institute of its kind in India for carrying out such tests. The fire impact test involved heating the FRRC in a furnace to 1010°C (1800°F), dropping it from a height of 4 metres and subsequently heating it again in an inverted position to 1010°C (1800°F). The fire endurance test involved heating the FRRC in a furnace at a standard time temperature curve for two hours while constantly monitoring the temperature inside. During this test, the inside temperature remained well below 177°C (350°F), the temperature at which paper begins to char.
- ↳ **Secure locking** : The door of the Godrej FRRC is secured by a strong bolt-work mechanism which, by the turn of a handle, throws a total of 8 bolts into the body in all four directions. The bolt work in this position is locked by a Godrej 6-lever dual-control lock. Stainless steel keys are provided in duplicate.
- ↳ **Attractive finish for elegant looks** : The Godrej FRRC comes with an attractive charbrown colour in stipple finish that complements any decor. Additionally, it is provided with an off-white painted panel and chromium plated brass handle. A superior anti-rust pretreatment and oven-baking process provides lifelong durability.
- ↳ **Cost-effective storage capacity** : The Godrej FRRC has a net effective storage volume of 640 litres (22 cubic feet)

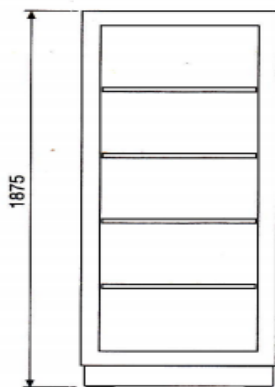

SEC. FRONT VIEW

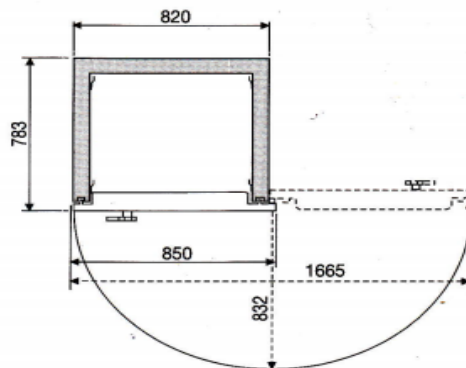

SEC. PLAN FRONT VIEW

## Specifications

	Height	Weight	Depth
Outside (mm)	1875	850	783
Inside (mm)	1620	670	589
Net Weight (Kg)	590		
Gross Weight (Kg)	650		

Tolerances- Weight: ±5% Dimensions: ±2%  
All dimensions and weights are in metric system and are approximate.

# SAFE DEPOSIT LOCKER CABINETS



## Features

Safe deposit locker cabinets for safe deposit vaults provide solid protection to valuables, from thefts of any kind.

### Features

- ↘ Fabricated from plates of prime quality tested steel
- ↘ Brass Levers are actuated by phosphor bronze springs
- ↘ Locks protected by a solid steel door, with no part protruding out
- ↘ State-of-the-art twelve-tank anti-corrosion treatment for all steel components
- ↘ High quality enamel paint coating, oven-baked under controlled conditions for scratch resistant finish
- ↘ Available with individual lockers in 10 different types and over 1600 combinations
- ↘ Optionally could be made available with Jewel Boxes and Renters Personal Lock

### Related Information

#### Usage

Banks Vaults, Private Vaults, Hospitals, Post offices, Hotels, Clubs



## Specifications

Total Quantity of Safe Deposit Lockers(per unit) - 75 Overall Dimensions h x w x d (mm) - 2000 x 1075 x 575

## Locking system

➤

The opening of the locker is jointly controlled by the custodian and the renter, each provided with a separate key

➤

Locks are interchangeable, so that locks of vacated lockers can be replaced easily

➤

For additional security, a special Renters personal lock for the renter with only one unique key to prevent unauthorized access can be provided

➤

Optionally, padlocking hasps can also be fitted on all locker doors enabling renters to use their own padlocks

## Accessories

➤

Also available, accessories like movable inspection tables, step ladders, key cabinets, low settees, and steel sleepers (to keep lockers away from direct contact with floor)

## Certification

➤

As per IS 5442:1991

➤

Approved and listed by the Bureau of Indian Standards (BIS)

## SDLC Accessories



Renter Personal lock



Steel Sleepers



Low Settee



Keyhives



Movable Inspection table



Movable platform with step ladder

Internal	TYPES OF INDIVIDUAL LOCKERS IN GODREJ SAFE DEPOSIT LOCKER CABINET 1											Total Qty. of S. D. Lockers (Per Unit)	Overall Dimensions of S. D. L. Cabinet in m.m (approx.)	Net Weight in Kgs. (approx.)				
	A	B	C	D	E	F	G	H	H1	L	L2							
In mm.																		
Height	125	159	125	189	159	278	189	321	321	404	385							
Width	175	210	352	263	424	352	530	424	210	530	530							
Depth	492	492	492	492	492	492	492	492	492	492	492							
Type of S.D.L. Cabinet	QUANTITY OF S. D. LOCKERS																	
1	66		6			3										75	1075 x 2000 x 575	695
1A	90															90	1075 x 2000 x 575	715
2		46			2			2	1							51	1075 x 2000 x 575	605
2B		60														60	1075 x 2000 x 575	655
3				28				2						2		32	1075 x 2000 x 575	535
1C/45			45													45	1075 x 2000 x 575	655
1F/21						21										21	1075 x 2000 x 575	525
3D/40				40												40	1075 x 2000 x 575	560
3G/20								20								20	1075 x 2000 x 575	520
L2/10**														10		10	1075 x 2000 x 575	475
1A/UB/18	18															18	1075 x 400 x 575	135
1A/UB/24	24															24	1075 x 525 x 575	180
1A/UB/30	30															30	1075 x 650 x 575	225
H/UB/12								12								12	865 x 2000 x 575	408
E/SP/24					24											24	865 x 2000 x 575	460
H1/SP/30									30							30	1075 x 2000 x 575	525

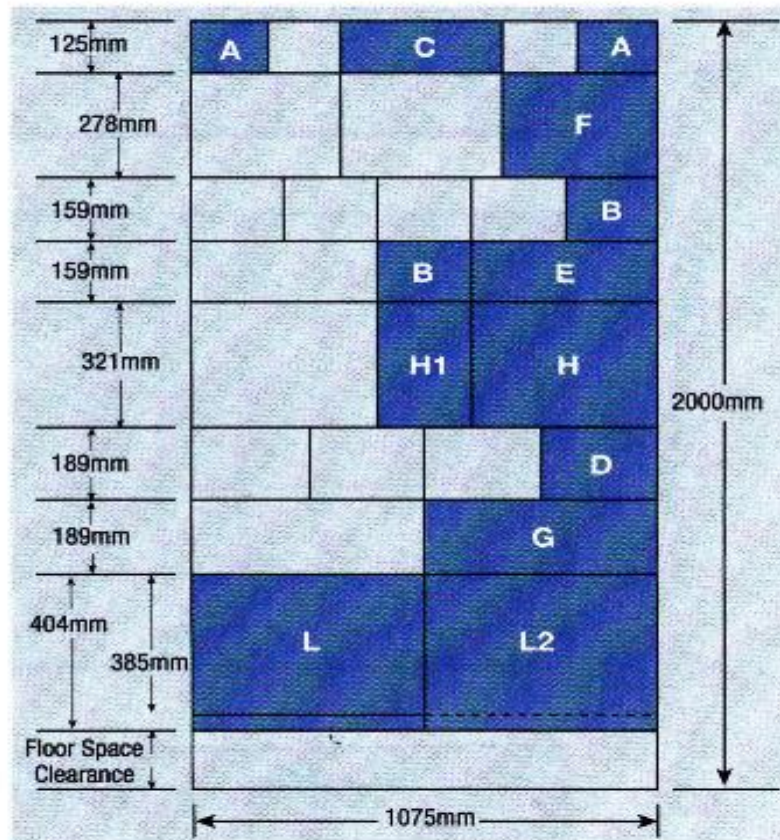

(Floor space clearance variable in different configurations)

# DEFENDER PLUS STRONG ROOM DOORS



Godrej has introduced a new range of Strong Room Doors to help Banks and financial institutions meet their security requirements. The Defender Plus Class I equivalent of Class M (as per UL 608) doors is recommended for small to medium size safe deposit locker installations. The Defender Plus Class II equivalent of Class I (as per UL 608) doors is recommended for larger vaults as well currency chests.

## Features

➤ **Defender Plus Class I Door Slab** : The thickness of the overall composite slab is 18mm made of a layer of flame and arc resistant (special) alloy which provides dependable protection against fire and attacks of power drilling, oxyacetylene flame and arc cutting. It is further fortified by a composite 62mm layer of Godrej Double Duty Barrier material. This dual protection is provided over the entire lock case area. The total thickness of protective layer is 85mm over the locks and other vital parts of the door. These Class I doors qualify as TRTL 15 of UL standards and Class 'C' as per BIS (IS 11188) standards.

➤ **Defender Plus Class II Door Slab** : This door has a 25mm slab of Torch and Drill Resistant Matrix Slab. A 65mm layer of Godrej Double Duty Barrier further fortifies this slab, making it virtually invincible from attacks of sledge hammers, hydraulic jack, power drills, torch and oxyacetylene flame. The total thickness of the protective layer over the locks and other vital parts is 105mm. These Class II doors qualify as TRTL 30 of UL Standards & Class 'B' as per BIS (IS 11188) standards.

➤ **Door Frame** : Tested quality 10 mm thick M.S. plate is used for fabricating the one piece bent angle door frame. For strength and rigidity the door frame is suitably reinforced along the height and width. A special 'Solid-jamb' is bolted to the frame.

➤ **Locking System** : Option of 2Nos. UL listed Lagard 4-Wheel Combination Lock, each capable of 100,000,000 codes/Two superior quality dual control High precision 8-lever locks made of Brass levers and actuated by Phosphor Bronze springs.

Highly sensitive spring loaded re-lockers on both the locks ensures deadlocking in the event of an attack either mechanically or by use of liquid explosives. The re-lockers are offered dual protection by the TDR Matrix and DDB. The locks are further protected by a drill defeat shield.

UL listed Time Lock may be fitted as an optional feature. Other lock options include 4 - Wheel UL / VdS listed Mechanical Combination Lock; Electronic Combination Lock and Biometric Lock.

➤ **Performance Standard** : The Defender Class II Strong Room Doors may be Classified -TRTL-30 Approved and listed by Bureau of Indian Standards as CLASS 'B'.

➤ **Protection against fire** : Godrej Double Duty Barrier material provides reliable protection against fire.

➤ **Automatic re-locking devices** : This feature offers additional security, incase an attempt is made with the help of explosives or mechanically. This sensitive device gets actuated automatically and the door is deadlocked which cannot be opened.

➤ **Drill Defeat Shield** : Locks and re-locking devices are protected by a specially designed drill defeat shield which defeats the attempts to drill open the locks.

➤ **Extra tough bolt work mechanism** : To secure the door, 12 shooting bolts (each of 38mm i.e 1 3/8" dia) are provided, six in front and six at the rear which slide behind the tough "solid-jamb" rebate. The bolts can be activated simultaneously by the movement of the handle.

➤ **Impact resisting shaft for handle** : Attractively designed, convenient to use handles are fitted on an impact resisting shaft which is meant to defeat attempts to hammer it in another unique feature of Godrej Defender Plus doors.

➤ **Grille Gate** : A well-designed grille gate is provided, which is secured with Godrej high precision 8-lever lock, operable from inside as well as outside.

➤ **Anti - corrosion treatment** : All steel components are given a thorough twelve stage anti-corrosion treatment followed by rust inhibiting paint for greater.

Related Information

Certification

➤ **Approved & Listed by the Bureau of Indian Standards (BIS).**

SPECIFICATIONS		CLASS - I DOORS		CLASS - II DOORS	
		MAIN	EMERGENCY	MAIN	EMERGENCY
Recommended for wall thickness	Wt	305 - 380	305 - 380	380 - 460	380 - 460
Overall size H x W		2200 x 1220	994 x 1067	2250 x 1320	1094 x 1167
Clear opening	A	2003 x 910	764 x 757	2003 x 910	764 x 757
Door swing	B	1045	890	1045	890
Grille gate swing	C	1040	880	1040	880
Projection of door at 90°	D	1085	930	1085	930
Projection of door when opened at 180°	E	265	265	285	285
Overall width of door and frame for maximum clear opening	F	1850	1605	1900	1645
Overall width of door and frame when fully opened	G	2206	1895	2255	1945
Overall thickness	T	167	167	187	187
Overall thickness of door frame including grille gate	OT	265	265	285	285
Weight without packing	Kg.	900	390	1150	460
Weight with packing	Kg.	1020	480	1300	560
Shipping particulars:					
Case height		2330	1320	2360	1320
Case width		1320	1220	1400	1220
Case depth		525	520	535	520

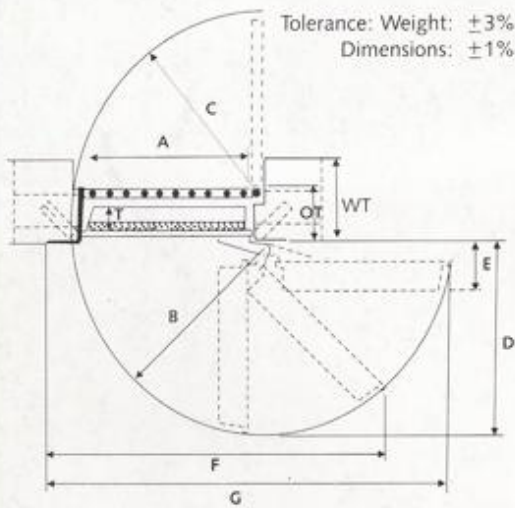

### Classification of Doors IS 11188:1991

IS 11188 Class	Torch & Tool Resistant (TRTL)	Godrej & Boyce Equivalent
SRDC	TRTL 15	CL I Defender Plus
SRDB	TRTL 30	CL II Defender Plus
VD/HSD A	TRTL 60	HSD 65 mm
VD/HSD AA	TRTL 120	HSD 90 mm
VD/HSD AAA	TRTL 180	HSD 150 mm

### Caution

It is mandatory to observe the following precautions in case Godrej Defender Plus doors are to be installed on the first floor or above:

1. The load carrying capacity of the floor must be ascertained from the structural engineer/architect concerned.
2. The strong room door must be installed directly above the beams only.

# VAULT ACCESSORIES



Exhaust Fan, Air Ventilator and Cage & Twisted Steel Strips vault accessories to ensure security.

## Features



### Exhaust Fan

Dynamically balanced blades for even load on bearings, thereby extending fan life

Polyurethane coating enables the fans to resist corrosion against chemically charged atmosphere and saturated humid conditions

100% waterproof and 100% dust-proof, the fans are manufactured with special constructions to meet IP: 55 degree of protection as per IS: 4691/1968 for outdoor applications and dusty environment

Conforms to IS specification 2312-1967

Motors with class B insulation to ensure operation at a high temperature



### Air Ventilator and Cage

Has two plates of 571mm sq each, one on the outside and one on the inside

The outer plate is a composite of 10mm MS plate, 5mm Aluminum plate and 5mm MS plate; while the inner plate is a 10mm MS plate

Both plates have 71 holes of 20mm diameter

Provision for fixing suitable exhaust fan on both sides of the ventilator

Collapsible type ventilator to suit any wall thickness between 300mm to 460mm

Two staggered 5mm thick baffle plates in between to obstruct direct access from outside



### **Twisted Steel Strips (Tang Bars)**

1830 mm x 227 mm x 3.15 mm thick MS Strips

Essentially to be used in twisted condition in 2 Rows in 'A' Class Currency Chests (as per RBI Classification)

Twisting to be done at site using Special Godrej twisting Machine

Normally 6.5 Nos. of Tang bars / M2 used up when laid in double rows



Related Information

Usage

Banks, Private Safe Deposit Vaults, Post Offices and Jewellers.

# CURRENCY BIN CABINETS



## Features

To help banks effectively utilise the strong room space, Godrej offers (Sliding Door) Currency Bin Cabinets.

### Features



Designed to maximise available storage space.



Well-designed locking mechanism for adequate security, ensuring convenient and independent access to each bin.



Manufactured from prime quality, cold-rolled, close-annealed steel.



Machine-formed multiple-bend construction for strength.



Interlocking and welding used for joining components, eliminates use of fasteners or rivets.



Sliding doors leaf of each Bin is fitted with two precision engineered Godrej 6 lever locks to facilitate dual custody.



A hasp and staple arrangement on each door allows each bin to be controlled by 2 or 3 persons as desired.



Unique colour indicator flags to indicate locked, unlocked condition.



Available in 3 sizes and storage capacities.

- 6-bin: 1472x1830x760

- 4-bin: 990x1830x760

- 4-bin (special): 990x1016x760



Also available special size Bin Cabinets for use in Fire and Burglar Resisting Steel Fabricated Strong Rooms meant for C Class Currency Chests. They maximise utilisation of Steel Fabricated Strong Room space.



Storage capacity of each bin for currency notes bundles:

Bin Cabinets	Denomination Of Currency (Rs.)				
	5	10	20	50	100
Standard size (Bundles of 1000 notes)	245	210	210	180	150
Special size (Bundles of 1000 notes)	245	210	210	180	150

## Related Information

### Usage

Banks, Private Safe Deposit Vaults and Financial Institutions.





# SAFES WITH COIN SLOTS

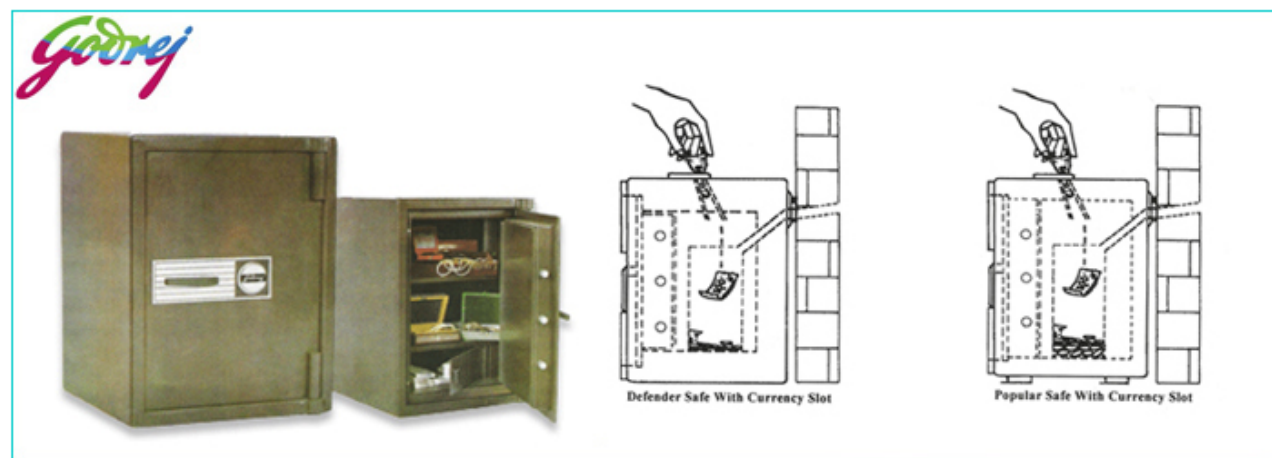

## FEATURES

### Defender Safe (Fire & Burglar Resistant)

Strong, seamless double-walled body with a specially formulated Double-duty barrier material for fire and burglar protection.

Optional keyless numerical combination lock with one million combinations.

Fitted with Godrej superior quality, dual control, high precision 8-lever lock.

A special drill defeat shield in the door in addition to an armour plate for extra protection

An automatic relocking device deadlocks the safe when an attempt is made to break open the lock through the keyhole either mechanically or with liquid explosives

Options

- With a locker with a flap door (26 Def Safe) or a drawer (31 & 41 Def Safes)
- Horizontal entry instead of top entry.

### Popular Safe (Burglar Resistant)

Single section multi-bend which is fully welded, making it the strongest safe in its class.

Provides drill-resistant armour plate protection.

Fitted with a Godrej dual control, high precision 6 lever lock.

Can be bolted to the floor.

Options

- With a locker with a flap door
- Horizontal entry instead of top entry.

Model	Defender Safes			Popular Safes	
Technical Information	26"	31"	41"	27"	22"
Outside : Height mm	660	790	1040	685	560
Width mm	535	635	635	535	460
Depth mm	545	650	650	510	460
Inside : Height mm	460	590	840	615	490
Width mm	330	435	435	530	455
Depth mm	295	395	395	420	370
Net Wiegth (Approx.) Kg.	395	590	750	90	70

# D'CAB RANGE - DEPOSITORY SAFES

